

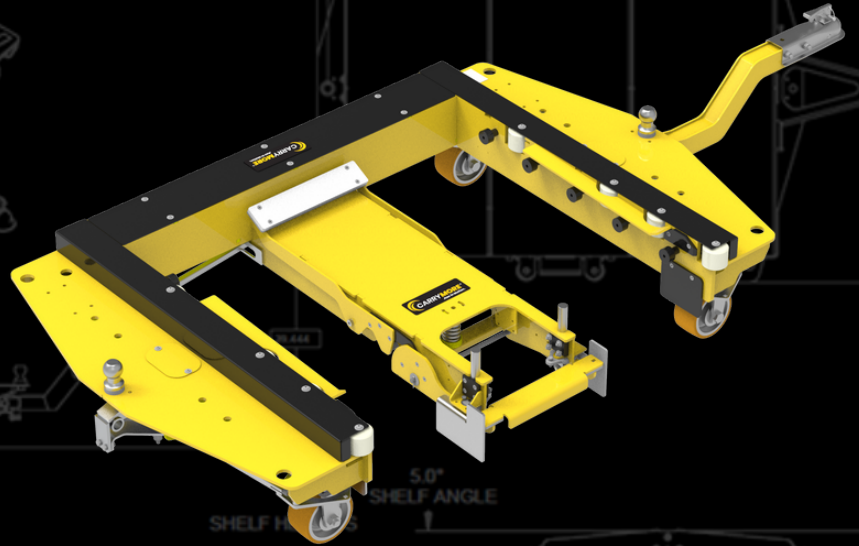

TQSA-40

MOTHER CART

Quad-Steer Designed For Precision Tracking



66" x 50"

Largest Recommended Cart



4,000 LBS

Weight Capacity

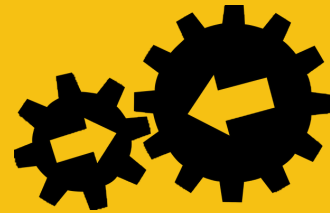

"A"

CarryMore Compatible

MODEL NUMBER	TQSA-40
TARE WEIGHT	675 lbs
CAPACITY	4,000 lbs
STEERING	Quad-Steer
ELEMATE	1.0"
MAX SLOPE	<9.5%
DECK HEIGHT	17"
DECK WIDTH	50"
DECK LENGTH	66"
MAX SPEED	5 MPH
MAX TRAIN WEIGHT	10,000 lbs

Our most popular "A" size Mother Carts, using Elemate 1.0, carries Daughter Carts up to 66" with superior tracking. Most commonly paired with 50" x 50" Daughter Carts, this Mother Cart works best with 48" x 45" knockdowns or standard size pallets.

Other features include a quick-change reusable tongue allowing the cart to be pulled in either direction with a standard 2" ball coupler latching system.

Compatible Daughter Carts include:

- RAFF-5050-40
- RAFF-5050-40-MBD
- RATT-5050-25
- RAKC-3933-25
- RARC-5050-20
- RAOU-3230-15
- RARH-1.1CU-10
- RAFF-6650-40

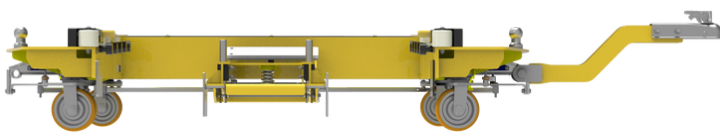

SCAN ME